



FEM3500 Series

Electromagnetic locks



The FEM3500 is an unmonitored single magnetic lock and FEM3500D is an unmonitored double magnetic lock with dual 12 or 24 Volt settings.

The FEM3500M is a monitored single magnetic lock and the FEM3500DM is a monitored double magnetic lock both with 12 or 24 Volt settings. Each monitored magnetic lock has a built-in Hall Effect Sensor for remote monitoring of Lock status (LSS). The devices have a highly visible high luminosity Light Panel and a Door Status Sensor (DSS) for remote monitoring of the door status as well as Lock Status Sensor (LSS). The monitored devices come with a patented Anti-Tamper-Security-Plate as standard to prevent hostile attacks on the dome nut-fixing bolt of the Armature Plate.

All FEM3500 Series Electromagnetic Locks come with a lifetime warranty and have no residual magnetism.

Features

- Door and Lock Status Monitoring Sensor (DSS and LSS)
- Built-in varistor (MOV) surge protection
- CE/C-Tick
- Anti-tamper plate (with "M" models)
- Long distance Light Panel (LP)
- Guaranteed no residual magnetism



| Warranties | |
|------------|--|
| Mechanical | Lifetime |
| Finish | allegion.co.nz/finisheswarranty |
| Electronic | 1 year |

Technical specifications

| Model | FEM3500(Single) FEM3500D(Double) | FEM3500M(Single) FEM3500DM(Double) | FEM3500FM (Flush Mounted) |
|-------------------|---|---|---------------------------|
| Holding strength | UP TO 280KG | | |
| Voltage / Current | Dual Voltage 12/24VDC, 12VDC= 500mA (Double x2) | | 24VDC= 250mA (Double x2) |
| Approvals | 4-hour fire rated to AS and BS Standards | | |
| Monitoring | N/A | LP LSS DSS | LSS |
| Dimensions | Single door series magnet: 238mm (L) x 48mm (W) x 25mm (D) Single door series armature plate: 185mm (L) x 38mm (W) x 12mm (D) Single door series DSS-armature plate: 185mm (L) x 38mm (W) x 12mm (D) | Double door series surgace magnet: 477mm (L) x 48mm (W) x (25mm (D) Double door series armature plate: 185mm (L) x 38mm(W) x 12mm (D) x 2 pieces Double door series DSS-armature plate: 185mm (L) x 38mm (W) x 12mm (D) x 2 pieces | |

Mounting details

FEM3500D & FEM3500DM

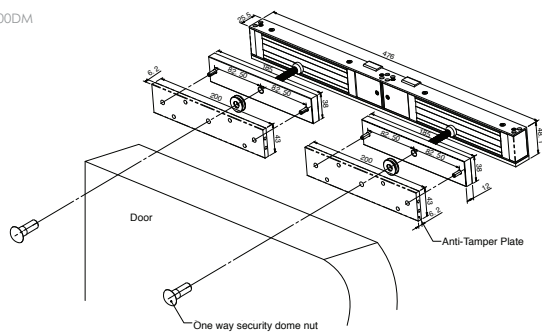

FEM3500 & FEM3500M

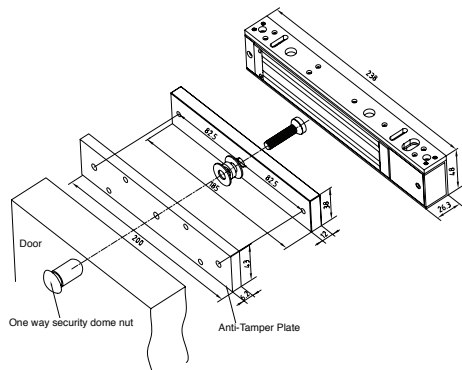

FEM3500FM

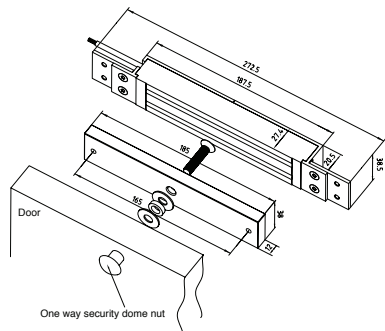

Testing and Compliance



Fire:

Tested to 4 hours on fire door assemblies as specified in AS/NZ 1905.1 – 1997 Part 1 Fire Resistant Doorsets